

8 | 7 | 6 | 5 | 4 | 3 | 2 | 1

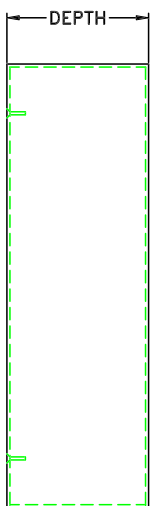

SIDE

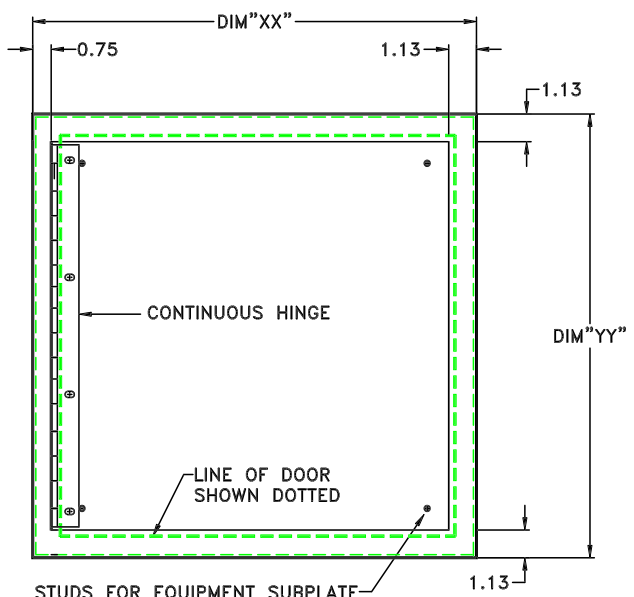

BACK BOX FRONT VIEW
16 GA. CRS

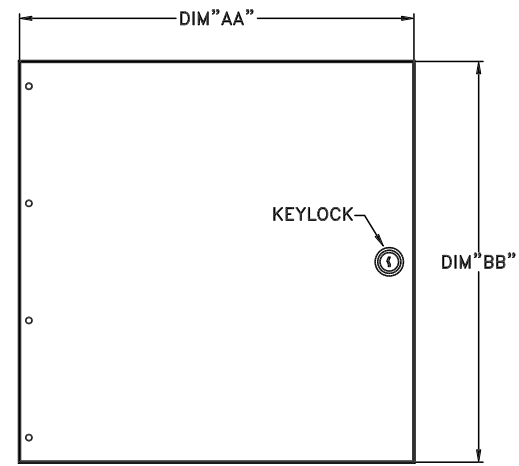

PANEL DOOR
.125" ALUMINUM

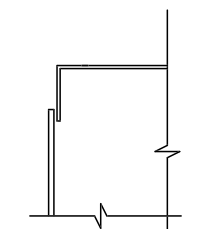

TOP SECTION
(BOTTOM SIMILAR)

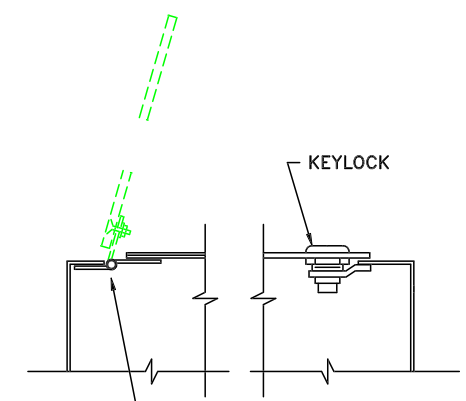

CROSS SECTION
(ASSEMBLED VIEW)

PART #	DIM "YY"	DIM "XX"	DIM "BB"	DIM "AA"	DEPTH
NG1818A-BOX	18.00	18.00	16.25	16.00	5.75
NG1824A-BOX	18.00	24.00	16.25	22.00	5.75
NG2418A-BOX	24.00	18.00	22.25	16.00	5.75
NG2424A-BOX	24.00	24.00	22.25	22.00	5.75
NG2436A-BOX	24.00	36.00	22.25	34.00	5.75
NG3624A-BOX	36.00	24.00	34.25	22.00	5.75

** TWO KEY LOCKS REQUIRED FOR NG3624A-BOX

NOTES:

- 1) MATERIAL:
BACK BOX - 16 GA. CRS
PLATE - .125" ALUMINUM
- 2) FINISH:
BACK BOX - TEXTURED BLACK POWDER COAT
PLATE - CLEAR CHROMATE

FD AUTOMATION DISPLAYS INC.

SURFACE ENCLOSURE ASSEMBLY

D	DRAWN BY	SMS	DATE	REV NO.	DRAWING NO.
SCALE			1/14/08		NG-BOX

8 | 7 | 6 | 5 | 4 | 3 | 2 | 1

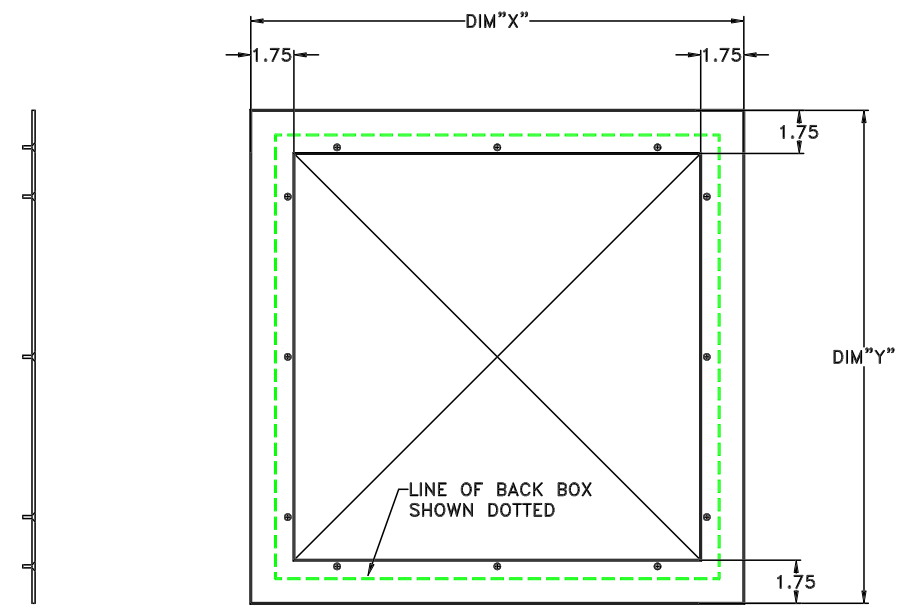

SIDE

TRIM RING
14 GA. CRS

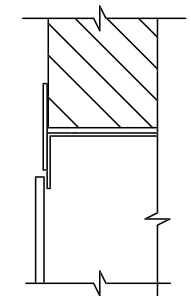

TOP SECTION
(BOTTOM SIMILAR)

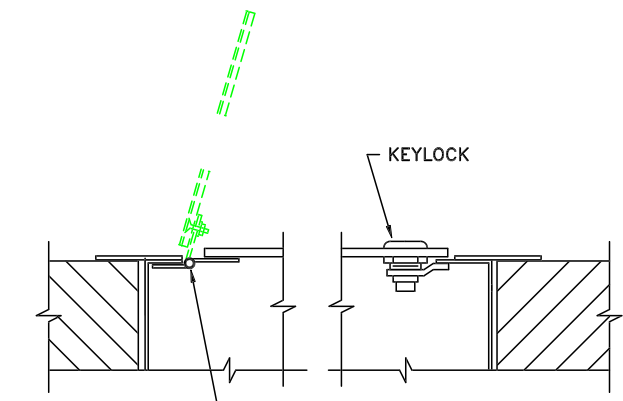

CROSS SECTION
(ASSEMBLED VIEW)

PART #	DIM "Y"	DIM "X"
NG1818A-TRIM	20.00	20.00
NG1824A-TRIM	20.00	26.00
NG2418A-TRIM	26.00	20.00
NG2424A-TRIM	26.00	26.00
NG2436A-TRIM	26.00	38.00
NG3624A-TRIM	38.00	26.00

- NOTES:
- 1) MATERIAL - 14 GA. CRS
 - 2) FINISH - TEXTURED BLACK POWDER COAT

NOTE:
SEE DRAWING #NG-BOX FOR
BASE ENCLOSURE ASSEMBLY

FD AUTOMATION DISPLAYS INC.

TRIM FOR FLUSH ENCLOSURE ASSEMBLY

D	DRAWN BY	SMS	DATE	REV NO.	DRAWING NO.
SCALE			1/14/08		NG-TRIM

8 | 7 | 6 | 5 | 4 | 3 | 2 | 1

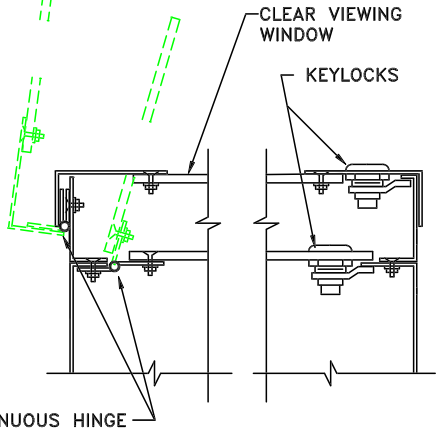
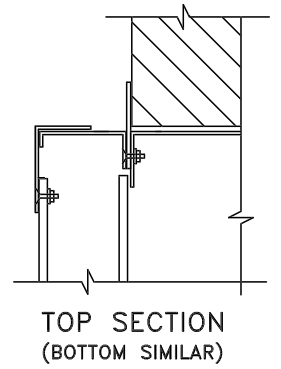
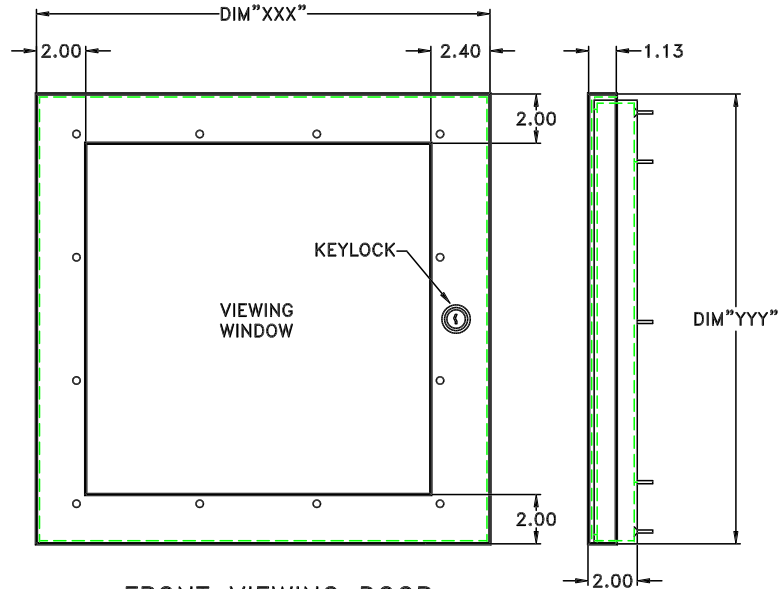
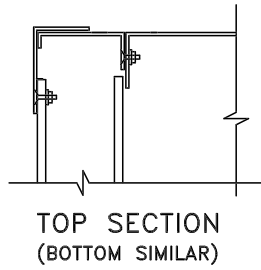

PART #	DIM'YYY'	DIM'XXX'	DEPTH
NG1818A-SECURITY COVER	18.25	18.40	2.00
NG1824A-SECURITY COVER	18.25	24.40	2.00
NG2418A-SECURITY COVER	24.25	18.40	2.00
NG2424A-SECURITY COVER	24.25	24.40	2.00
NG2436A-SECURITY COVER	24.25	36.40	2.00
NG3624A-SECURITY COVER	36.25	24.40	2.00

** TWO KEY LOCKS REQUIRED ON INNER DOOR FOR NG3624A-SECURITY COVER

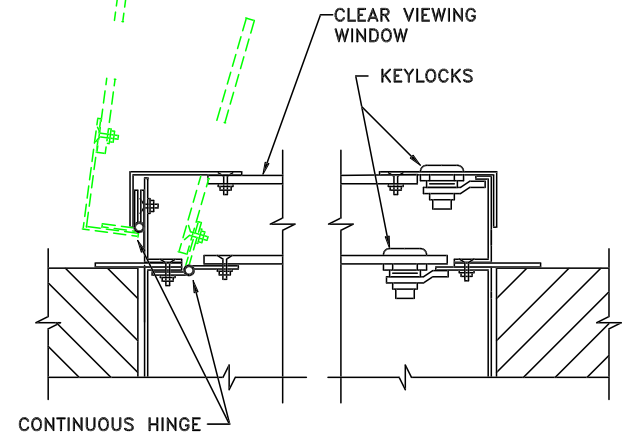

NOTES:

- 1) MATERIAL - 14 GA. CRS
- 2) FINISH - TEXTURED BLACK POWDER COAT

NOTE:

SEE DRAWING #NG-BOX FOR
BASE ENCLOSURE ASSEMBLY

FD AUTOMATION DISPLAYS INC.			
ENCLOSURE ASSEMBLY WITH SECURITY COVER			
D	DRAWN BY SMS	REV NO.	DRAWING NO.
SCALE	DATE 1/14/08	REV NO.	DRAWING NO. NGSEC-COVER

8 | 7 | 6 | 5 | 4 | 3 | 2 | 1